

# Classified Powershift - Third Party Wheel Build Manual

Classified cycling is a company that strives to be available to all, this means we do encourage you to build our Powershift hub into your favourite rims. Get the Powershift Hub kit with Hubshell and have your new wheels assembled at your local wheelbuilder.

The following Classified hubshell types are available on <https://b2b.classified-cycling.cc/eng/>

Hub width	Straight pull / J-Bend	Number of spokes	Disc brake type	Article number
142	Straight pull	24	Centerlock	HBS-SPNB-A00-A-00
148	Straight pull	28	Centerlock	HBS-SPOB-A00-A-00
142	J-Bend	32	Centerlock	HBS-JBNB-CA0-B-00
142	J-Bend	28	Centerlock	HBS-JBNB-BA0-A-00
148	J-Bend	32	6-Bolt	HBS-JB0B-CB0-A-00

**NOTE:** The Classified Hubshell requires specific drilling angles of the rim's spoke holes for having the best possible wheel build. By not selecting a Classified compatible rim you will be voiding the warranty on every build with the Classified Hubshell. Please check the 'Drilling Angle Section' if your rim of choice is not present in the list of compatible rims. You could check for compatibility of your rim of choice.

## ⚠Disclaimer⚠

This document provides necessary information about how to build a wheel with the Classified Powershift Hub, please read the whole document before attempting to build your wheel.

All remarks and instructions in this document have to be followed for user safety. Classified will only warranty the hub if used correctly and the wheel and bike will comply with all requirements listed below.

This disclaimer is valid for everyone attempting to build a wheel with the Classified Powershift Hub such as: professional wheel builders, bike shops and end consumers alike.

## Drilling angle section

Required information:

- ERD (Effective Rim Diameter) supplied by the rim manufacturer
- Drilling Angles from the rim manufacturer
- Drilling Angle Tool from Classified

Procedure:

- Select the Hubshell type in the tabs at the bottom of the screen
- Insert the ERD in the 'USER INPUT' box (see below for Symmetric rims)

NOTE: For asymmetric rims use the bottom table and insert the offset in the user input box

Symmetric Rim		Allowed tolerance on drilling angles is $\pm 0.5$ degrees				
Rim Height [mm]	Effective Rim Diameter [mm]	ERD	DS Angle 1 [Degrees]	NDS Angle 2 [Degrees]	Angle 3 [Degrees]	Angle 4 [Degrees]
20	600		3,9	6,6	8,7	4,8
30	580		4,1	6,8	9,0	4,9
40	560		4,3	7,1	9,4	5,1
50	540		4,5	7,4	9,7	5,3
60	520		4,7	7,7	10,1	5,5
65	510		4,8	7,9	10,3	5,6
USER INPUT	539		4,5	7,4	9,7	5,3

- Asses the drilling angles of the Classified Drilling Angle Tool to the rim manufacturer's drilling angles.

## Wheel build procedure:

- The hubshell should be assembled using a Dummy Hub supplied by Classified Cycling or a Powershift Hub with the Torque support arm mounted (see in picture below).

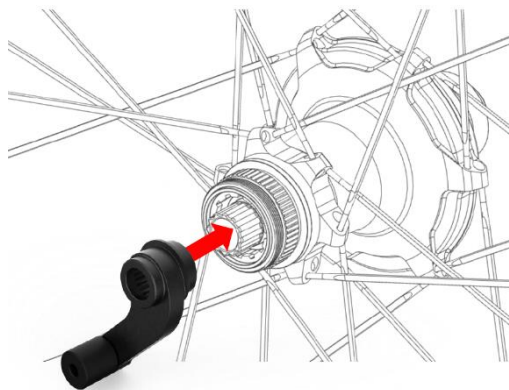

Dummy hubs are available on <https://b2b.classified-cycling.cc/eng/>

Hub width	Article number	Compatibility
142	DUM-0142-A00-A-00	Road/Gravel
148	DUM-0148-A00-A-00	XC/Gravel
148	DUM-0148-A00-B-00	Enduro

- Maximum spoke tension for the hub shell is 120kg
- Determine the spoke length using the tables on the following pages

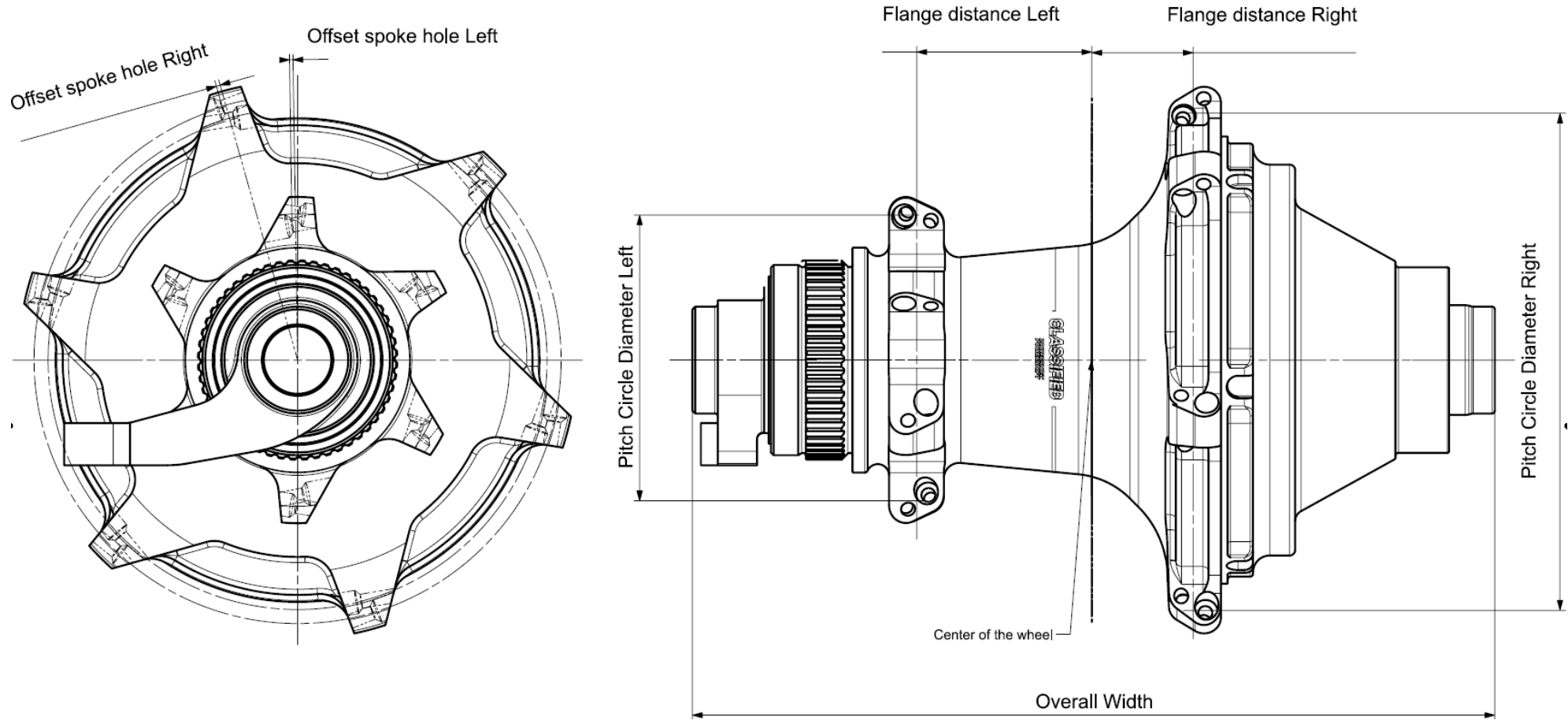

Classified Hubshell Straight Pull									
Overall width	Number of spokes	Spoke ratio (Left/Right)	Pitch Circle Diameter		Flange Distance		Offset spoke hole		Spoke hole diameter
			Left	Right	Left	Right	Left	Right	
142	24	1:1	50	91,2	31,75	17,5	0,65	0,7	2,5
148	28	1:1	45,6	90,05	32,1	20,1	1	1,3	2,5

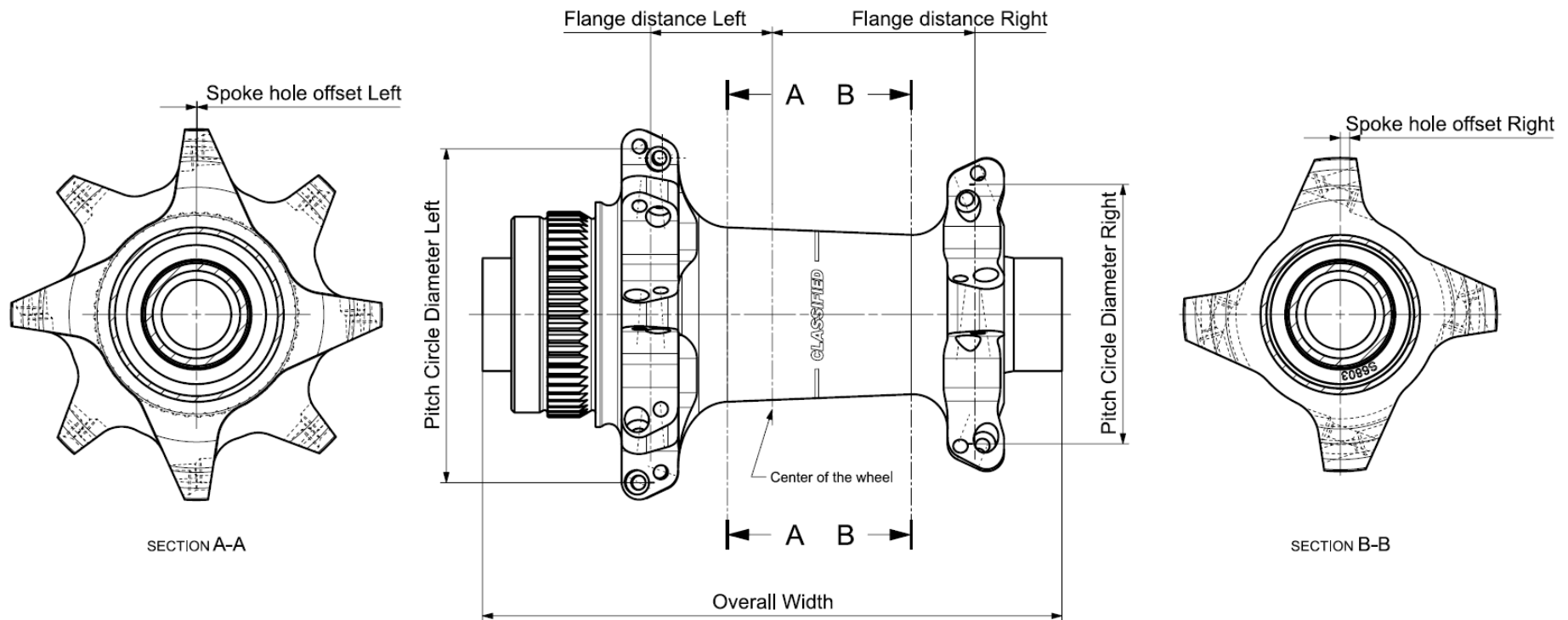

Classified Front hub Straight Pull									
Overall width	Number of spokes	Spoke ratio (Left/Right)	Pitch Circle Diameter		Flange Distance		Offset spoke hole		Spoke hole diameter
			Left	Right	Left	Right	Left	Right	
100	24	2:1*	56	43	21	35	0,1	1,6	2,5
110	28	1:1	44,6	38,7	25,4	32,3	0,8	1,1	2,5

\*Due to the 2:1 spoke pattern, the following procedure has to be followed to determine the spoke lengths  
 For the Non-Drive Side (NDS), select 28H with 3-cross. For the Drive-Side (DS), select 16H with 1-cross.  
 Following spoke calculator is advised: <https://blackjackwheels.com/spoke-calculator/>

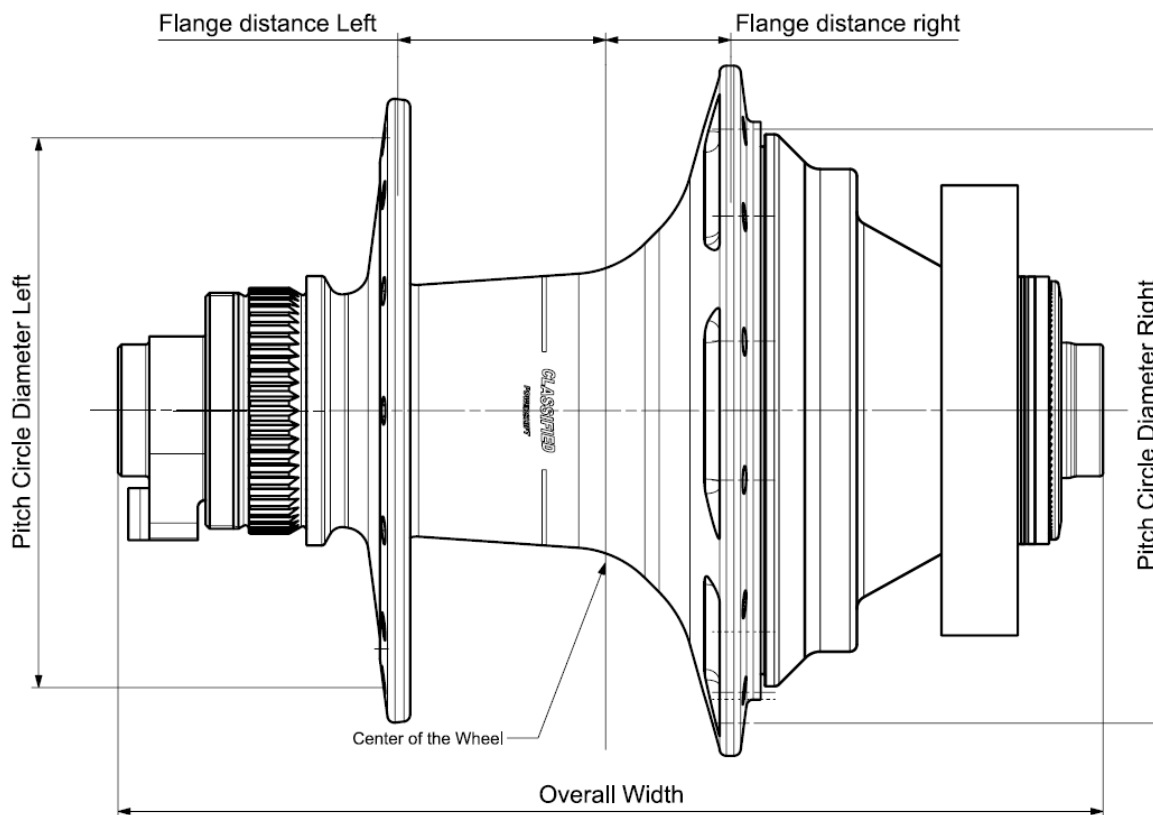
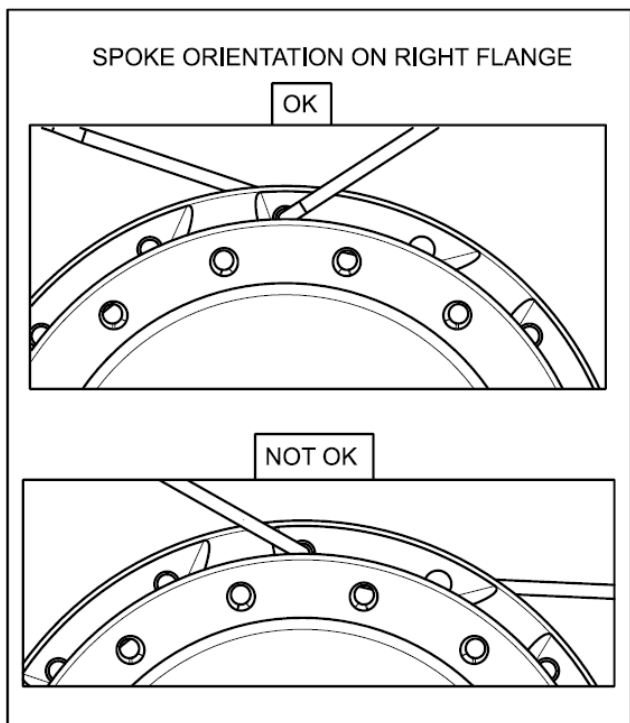

Classified Hubshell J-Bend							
Overall width	Number of spokes	Spoke ratio (Left/Right)	Pitch Circle Diameter		Flange Distance		Spoke hole diameter
			Left	Right	Left	Right	
142	28 / 32	1:1	80	90	30	17,8	2,8